

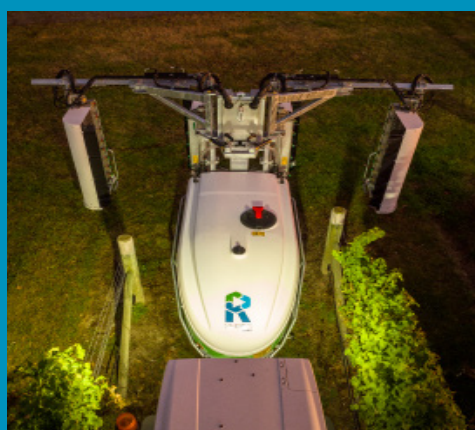

SPRAYERS
& EQUIPMENT

TRS 2-ROW RECYCLING SPRAYER



TRS R-SERIES 2-ROW SPRAYER

MODEL NAME: R2-2300, R2-3000, R2-4000

The TRS R-Series Recycling Sprayer takes a great concept and makes it even better! Building on the original award winning FMR R-Series released in 2010, the recently re-branded TRS machine introduces a number of new features and innovations that make owning and operating this machine in your vineyard even more beneficial.

Features include:

- Shroud design with fold down sump in base for rapid cleaning of filtration screens
- Shroud design is quickly and easily dismantled for ease of servicing
- Tank design provides improved weight distribution for stability
- Boom system provides improved functionality and flexibility
- Pumps and valves slide or fold out, making servicing simple and easy
- Overall maneuverability and stability improved with overall height and length reduced and centre of mass lowered
- Improved tank level indicator located on rear frame
- Improved hydraulic system for greater efficiency and function
- Auto rate controller for improved operator comfort and control

FEATURES:

- Composite tank - 2300L, 3000L, 4000L options
- 200lt fresh water for flushing & hand wash
- Hot dip galvanised chassis & boom
- Weber tangential fans with 8 nozzle wet boom
- Automatic rate controller
- Proven R-Series delivery & recycling technology
- 100% hydraulic drive - just 57lt/min required
- Standard walking beam axle

Additional options available at ordering:

- Terrace configuration: hydraulic height adjustable booms with individual L/R (only available on 2-row with tandem axle) Model Name: RT2-2300, RT2-3000, RT2-4000
- 3-point pivoting hitch
- New heavy duty walking beam axle system
- Hydraulic brakes

BENEFITS:

- Addresses the environmental and social issues from off-target drift
- Enables savings of 25-40% of annual spray expenditure
- Huge savings in time from reduced refill occasions
- Increased application opportunity due to ability to operate in inclement weather conditions
- Multiple systems for enhanced operator comfort and safety

MODEL DIMENSIONS:

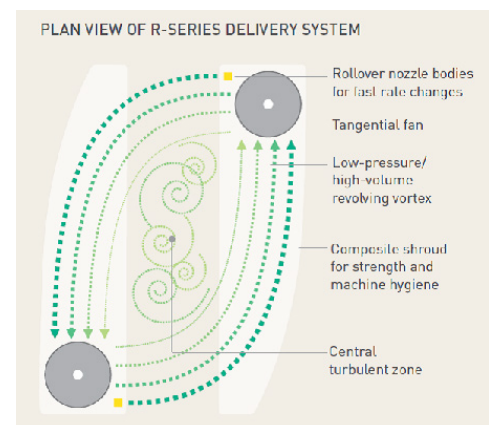
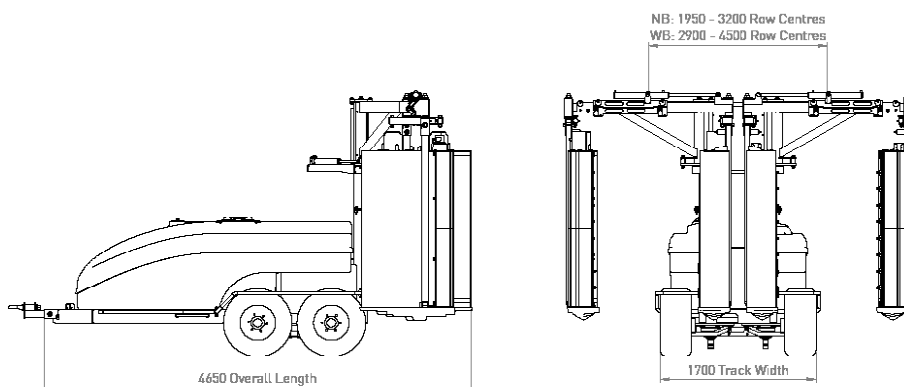

TRS Wholesale Limited

9B / 40 Waters Avenue, Blenheim 7201, New Zealand

Postal Address : PO Box 162, Blenheim 7240, New Zealand

Telephone : +64 3 572 5150 | Freephone: 0800 367 583

Email: sales@trswholesale.co.nz | trsequipment.co.nz

Your local dealer: